



ColorGrip®

ColorGrip® is a patented product.

Check our our ColorGrip® website at:
www.colorgrip.com

THE WORLD OF GASKETS JUST GOT BRIGHTER
COMPRESSION CONTROL
HANDS FREE IMPROVED GASKET ASSEMBLY
COLOR CODING



www.flowsmartinc.com

17 ROBERT ST., WHARTON, NJ 07885 PH: 973.537.6400 FAX: 973.537.7090

FEATURES OF THE COLORGRIP® GASKET

The ColorGrip® gasket is the most comprehensive sanitary gasket designed with a **compression stop**, **color coding**, and **alignment aid** for accurate assembly providing the ultimate assurance for alignment, Component Segregation, and it will eliminate issues caused by gasket intrusion.

Flow Smart Inc. has created the ideal marriage of polymers by combining a rigid mechanical stop comprised of a medical grade plastic, interlinked with our premier pedigree of elastomers engineered to provide the ideal hygienic seal. It is proven to achieve extended life with process fluids and steam applications.



SEAMLESS TRANSITION IN A STANDARD CLAMP CONNECTION

Achieving a clean contact surface is critical to high purity processing. The ColorGrip® is engineered to replace a conventional clamp gasket and prevent overtightening to establish an ideal elastomer to stainless steel transition at the sealing location.

With the ColorGrip® the elastomer will not extrude into the inside diameter of the process pipeline. The ColorGrip® accomplishes our goal by combining a hard stop with an elastomer. The rigid surface limits the load that the elastomer would typically be subject to.

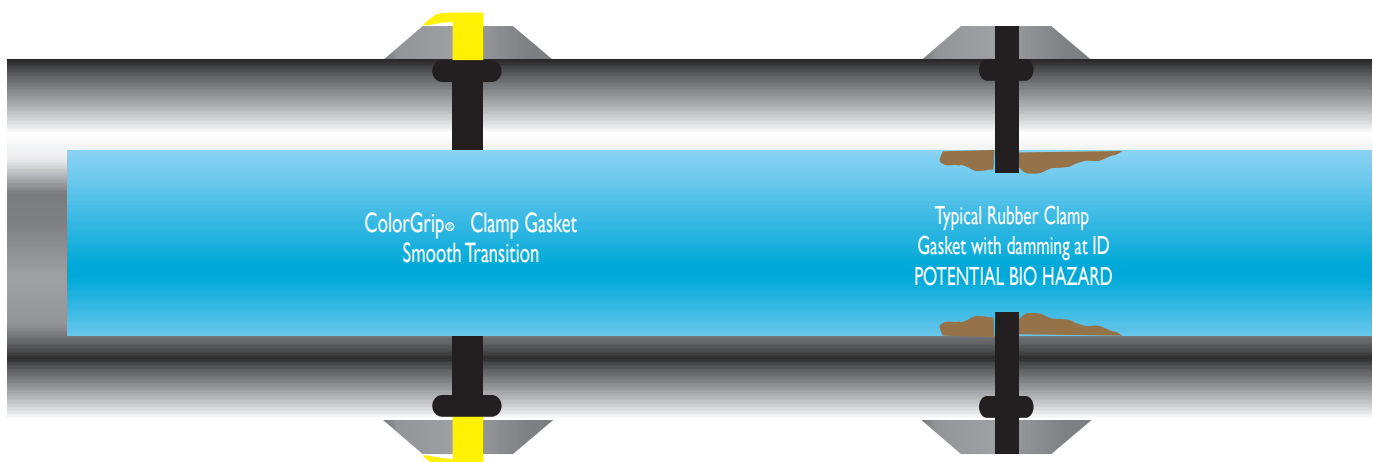

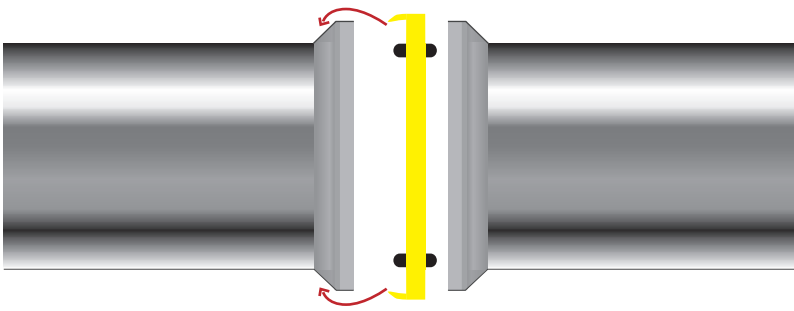

IT GRIPS!

The **GRIPPING** feature will make gasket assemblies more efficient. The ColorGrip® will stay in place while you use your hands to make up the assembly, helping to ensure the ideal alignment. This also limits the possibility of gaskets falling on process floors.

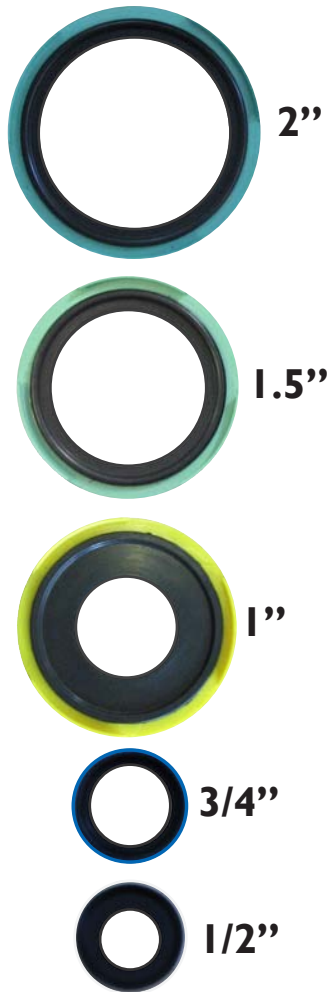

CHOOSE YOUR SIZE

WHY COLORS?

The ColorGrip® Gasket enables users to segregate process lines by color coding or to design SOP programs as an aid to control maintenance changes.

**Actual Colors May Vary. Call For A Free Sample!*

CHOOSE YOUR ELASTOMER

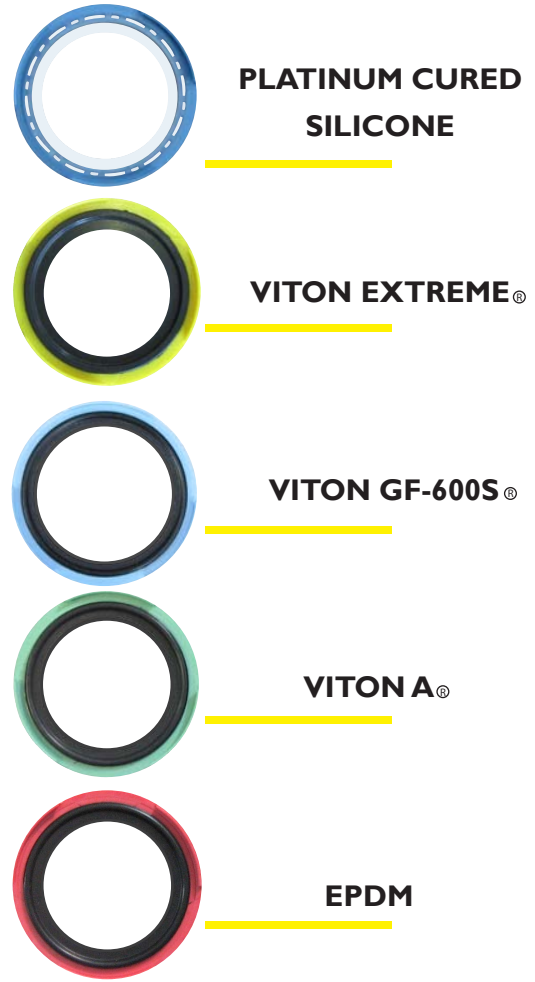

CHOOSE YOUR COLOR

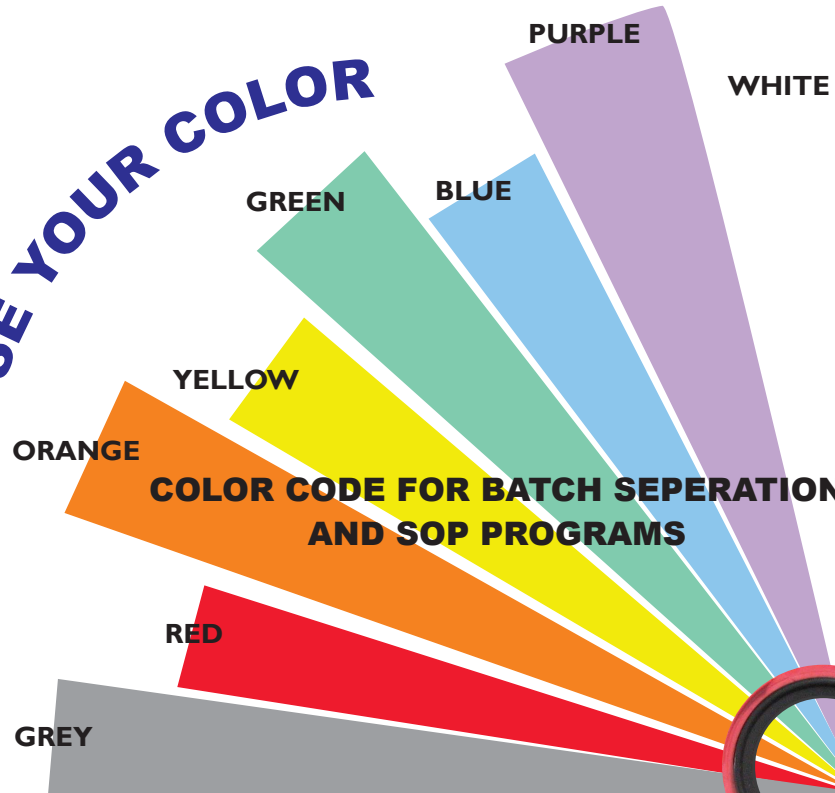

COLOR CODE FOR BATCH SEPERATION AND SOP PROGRAMS

PART NUMBER SYSTEM

GR	MATERIAL	COLOR	SIZE
"GR" for ColorGrip®	E = EPDM	BE = Blue	1/2" = 050
	V = Viton A®	YW = Yellow	3/4" = 075
	RXPX = Platinum Silicone	RD = Red	1" = 100
	VGf = Viton GF - 600S®	GN = Green	1-1/2" = 150
	VEX = Viton Extreme®	WE = White	2" = 200
	AF = Aflas	OE=Orange	3" = 300
		PE=Purple	

SMART SOLUTIONS IN A COLORGRIP® GASKET

The ColorGrip® is made in the USA.

Precision Engineered for the smoothest seal transition in a clamp design.

Extended life due to compression control.

FDA and USP Class VI Elastomers and plastic. Specifications available upon request.

Fully traceable materials documented on certifications.

Does not contain animal derived ingredients.

Hands free installation.
Easy on - Easy off.

The only color coded design of 1/2" and 3/4" Clamp gasket sizes.

Part Number Examples:

1/2" EPDM with Blue ColorGrip® would be: GR-E-BE-050
2" Viton® with Red ColorGrip® would be: GR-V-RD-200

Materials:

Plastic is comprised of Flow Smart's exclusive DuroLoc. DuroLoc is medical grade, FDA compliant, and USP Class VI tested material.

Elastomers:

EPDM peroxide cured: Flow Smart's peroxide cured EPDM has been tested to have the lowest extractables of a USP class VI EPDM gasket. Our EPDM is FDA compliant.

Viton A®:

Flow Smart molds genuine EI DuPont Viton A® for the ColorGrip®. Our Viton A® is USP tested and FDA compliant.

Viton GF-600S®:

A high performance Viton® material that has the greatest combination of steam and chemical resistance of any economical pharmaceutical/biotech grade elastomers.

Viton Extreme®:

A premier high performance Viton® material that can be chosen as a problem solver in extremely challenging chemical applications in the pharmaceutical and biotech industries.

Platinum Silicone:

Platinum Silicone is available in a variety of choices including DOW and GE Silicone brands. We produce our ColorGrip® using non-pigmented DOW Q7-4780.

Aflas:

Aflas is available as a problem solving compound with great range of both alkali and acid based solutions. Aflas also offers good steam resistance.

Viton® is a trademark of the EI DuPont Co.
ColorGrip® is a licensed trademark to Flow Smart Inc.

17 Robert St., Wharton, NJ 07885
Phone: 973.537.6400
Fax: 973.537.7090
www.flowmartinc.com
www.colorgrip.com



CG rev. 03-2007