

202F Ball Valve

2-Piece Full Port

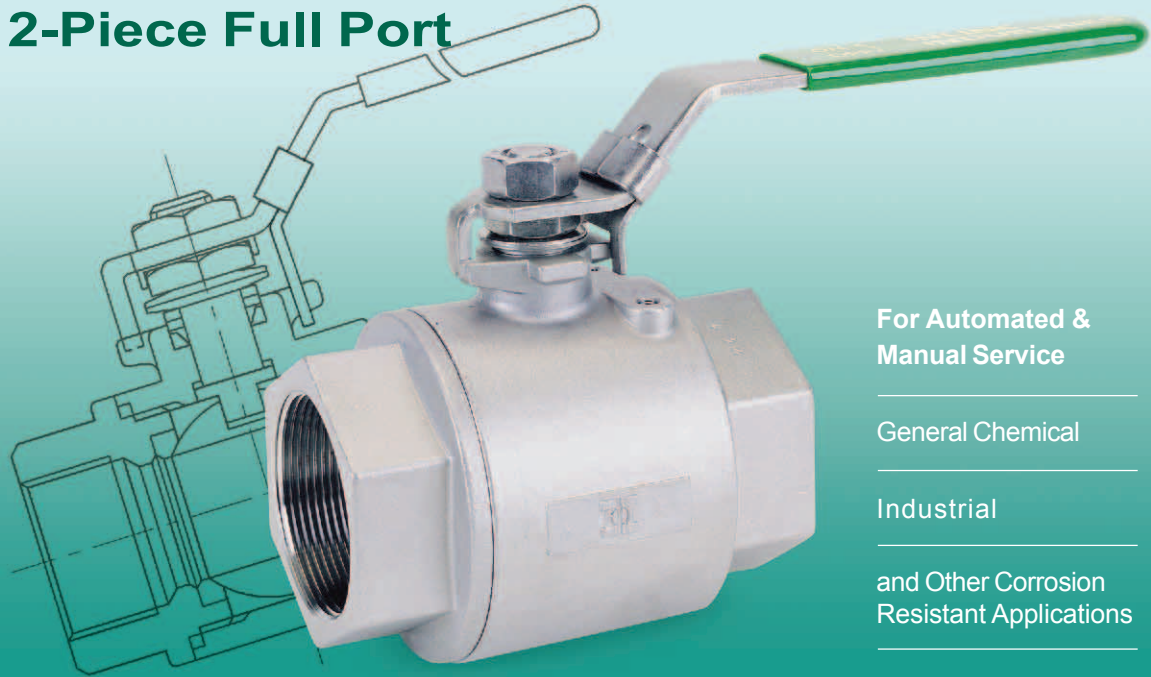

For Automated &
Manual Service

General Chemical

Industrial

and Other Corrosion
Resistant Applications

Standard Features and Benefits

- **Economical 2-Piece Design**
- **Full Port**
Improves flow resulting in increased process efficiencies
- **Blow-Out-Proof Stem**
Stem is bottom loaded to prevent removal when valve is in service
- **Live-Loaded Stem Packing**
Provides constant load on the stem seal and extends service life
- **Locking Device**
Enables plant personnel to secure valve in open or closed position when manually operated
- **Corrosion Resistant**
Made of 316 stainless steel (A351 Gr. CF8M) for superior chemical resistance and longer service life
- **Investment Cast**
Improves dimensional control and reduces porosity

202F Pressure / Temperature Chart
(RTFE Seats)

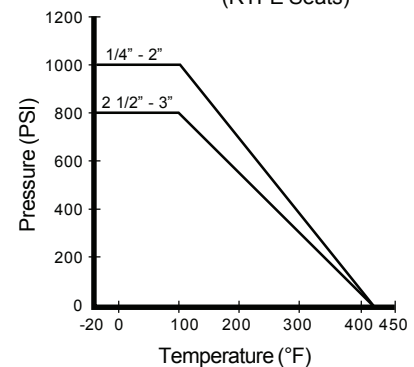

Operating Conditions

- Temperature range (RTFE):
-20°F ~ 420°F
- Maximum pressure (RTFE):
1000 PSI WOG (1/4" ~ 2")
800 PSI WOG (2 1/2" ~ 3")

Specifications

- All valves shell and seat tested to ANSI/ASME B16.34 and API 598

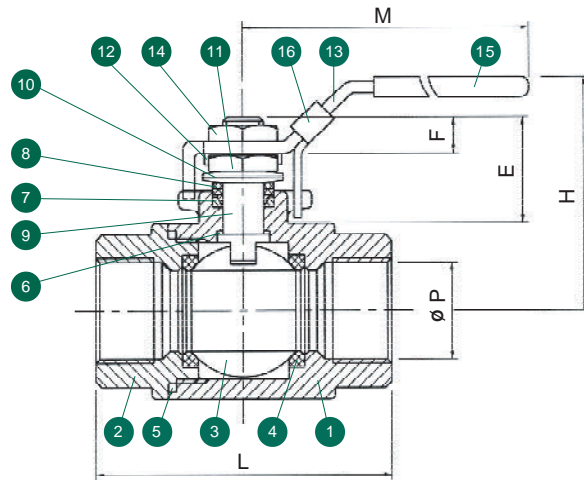
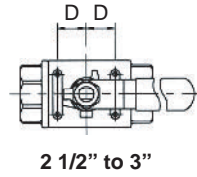
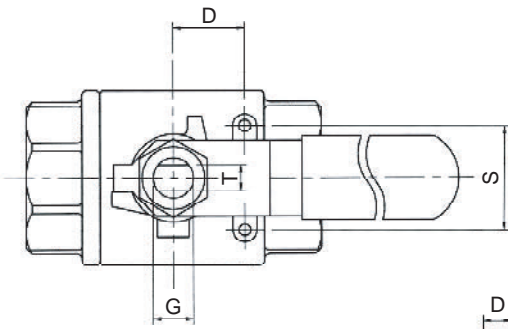

Valve Components			
#	Part Name	Material	Qty.
1	Body	A351 Gr. CF8M	1
2	End Cap	A351 Gr. CF8M	1
3	Ball	316SS	1
4	Seat	RTFE (15% G.F.)	2
5	Body Seal	PTFE	1
6	Thrust Washer	RTFE (15% C.F.)	1
7	Stem Packing Set	PTFE	1
8	Packing Gland	304SS	1
9	Stem	316SS	1
10	Belleville Washer	304SS	2
11	Gland Nut	304SS	1
12	Gland Nut Lock Washer	304SS	1
13	Handle	304SS	1
14	Handle Nut	304SS	1
15	Handle Cover	Vinyl	1
16	Locking Device	304SS	1

Dimensions (Inches)											
Size	L	P	H	E	F	M	D	S	T	G	Weight (lbs)
1/4	2.16	0.44	1.90	0.82	0.30	4.40	0.50	1.10	0.197	0.31	0.60
3/8	2.16	0.50	1.90	0.82	0.30	4.40	0.50	1.10	0.197	0.31	0.63
1/2	2.36	0.60	2.00	0.82	0.30	4.40	0.50	1.10	0.197	0.31	0.72
3/4	2.95	0.78	2.20	0.89	0.30	5.00	0.88	1.38	0.256	0.39	1.30
1	3.26	0.98	2.50	1.20	0.35	6.10	0.88	1.38	0.315	0.47	1.75
1 1/4	3.82	1.25	2.75	1.20	0.35	6.10	0.94	1.50	0.315	0.47	3.00
1 1/2	4.29	1.50	3.30	1.40	0.51	7.40	0.94	1.50	0.381	0.55	4.60
2	5.08	2.00	3.75	1.40	0.51	7.40	0.94	1.50	0.381	0.55	7.70

202F Ordering Information

Example: 2" Full Port Ball Valve with Lever Handle and Locking Device, 316SS Body and Trim, RTFE (15% G.F.) Seats and PTFE Seal, NPT Ends

202F	D	6	6	6	6	R	T	TT	2	S
Valve Series	Valve Size	Body Material	End Material*	Ball Material	Stem Material	Seat	Seal	End Connection	Port	Ball Config.
202F - Full Port	2 1/4"	6 - A351 Gr. CF8M (316)	6 - A351 Gr. CF8M (316)	6 - A351 Gr. CF8M (316)	6 - A351 Gr. CF8M (316)	R - RTFE (15% G.F.)	T - PTFE	T - NPT	2 - 2 Way	S - Straight Port
	3 3/8"									
	5 1/2"	2 - A216 Gr. WCB	2 - A216 Gr. WCB	6 - A351 Gr. CF8M (316)	6 - A351 Gr. CF8M (316)	C - RTFE (15% C.F.)	F - 50% 316SS Filled PTFE	7 - ASEV Ball		
	7 3/4"									
	A 1"									
	B 1 1/4"									
	C 1 1/2"									
	D 2"									

* End Material must be the same as Body Material
 Due to continuous product development, information may change without notice.

INLINE INDUSTRIES, INC.
 4701-A Littlejohn Street
 Baldwin Park, CA 91706
 Tel: (626) 813-6188
 Fax: (626) 813-6186
www.ballvalve.com
info@ballvalve.com

Distributed by: