



Sliding Gate Regulators



Globe & Cage Regulators



Pressure Regulators



Sliding Gate Control Valves



Control Valves



Temperature Regulators



Low Flow Valves



Fractional Flow Valves

Condensed Catalog

Standard valves are delivered within 36 hours while expeditious service is routine for special order valves.

Servicing the following markets: water resources, oil & gas, refining, petrochemical, chemical and power. Other sectors include: paper products, tire and rubber, machinery and electrical equipment, transportation equipment and power generation

Jordan Sliding Gate Valve Seats . . .

Simple Concept, Superior Performance

You'll notice something different in a Jordan valve . . . the sliding gate seat. A remarkably simple concept that offers sophisticated performance and benefits not found in traditional rising stem and rotary valves.

The sliding gate seat is made up of two primary parts: a moveable disc and stationary plate with multiple orifices. Together, this seat set achieves levels of performance, reliability and accuracy that are hard to find in other valve designs.

Straight-Through Flow

The control element in the Jordan Valve sliding gated design is perpendicular to the flow, unlike the traditional globe style design. With the straight thru flow design, the sliding gate design reduces turbulence and provides superior trim life.

The sliding gate design provides unparalleled low flow control since the flow works with the design, not against it. In a typical globe style design the flow goes underneath the plug, working against the plug. In the sliding gate design, the flow pushes the disc against the plate, helping to hold the desired setpoint. This also enables the disc and plate to lap and clean themselves. Thus the sliding gate design, wears in instead of wearing out!

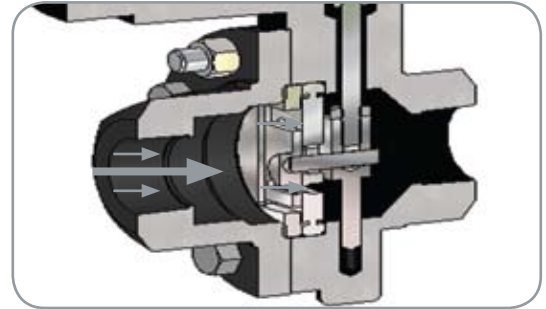

This unique ability provides much higher rangeability and better turndown while maintaining tight shut-off. When the valve is closed, the disc and plate form an area of closure, not a line of closure. The upstream pressure and a retaining guide combine to keep the disc and plate in constant contact, which eliminates the noisy chattering often encountered during valve operation. This construction also minimizes the hunting commonly found in conventional rising stem globe style valves.

Short Stroke, Fast Response

The total stroke length of a sliding gate valve is just a fraction of the equivalent globe or rotary style valve. In pressure regulators, the stroke length is typically 1/3 that of a globe valve, reducing the amount of droop in the regulator. In a Jordan control valve, the stroke length can be as low as 1/6 that of a conventional globe or cage guided design. This allows much smaller actuators, reducing air consumption and weight.

In both regulators and control valves, the response time from a change in the input signal is dramatically reduced. This also lessens the wear on the packing and lengthens the diaphragm life.

Quiet Operation

Quiet operation is a standard feature of Jordan sliding gate valves. Compared to conventional globe and cage designs, the sliding gate seat generates between 5-10dBa less noise. In addition, you won't find a premium price adder for "low-noise trim". The sliding gate valve is inherently quieter than other types of valves because:

- The disc and plate remain in constant contact, eliminating the chatter found in plug and seat designs
- The straight-through flow passage minimizes turbulence found in globe and rotary designs, a prime cause of valve noise
- The multiple orifices in the plate and disc divide the flow into smaller, noise-dissipating flow streams.

Tight Shutoff

The sliding gate design provides an area of closure, not a line of the closure. When the valve is closed, the disc and plate are overlapped by 1/32". This area of closure helps reduce the effects of wire draw which is one of the most common causes of seat leakage. What does this mean for you? Less maintenance down-time and more opportunity to increase yields and profits!

Why the Sliding Gate lasts longer than other designs:

- Area of closure – when closed, the disc overlaps the orifice in the plate approximately 0.030" (0,8mm) so that the seats actually move beyond the closed position. This overlap creates an area of closure not often found in globe/cage or rotary designs.
- Self-cleaning – The movement of the sliding gate seats generates a self-cleaning action, with any leak-producing deposits being cleaned off by the sharp shearing action of the disc moving across the plate.
- Materials – Our proprietary Jorcote seat material is extremely hard and delivers outstanding wear resistance. For more aggressive applications, a Jorcote/Jordanic combination provides extremely long seat life.
- Multi-orifice – The multi-orifice design separates erosive flow into smaller, less damaging streams. The erosive forces are dissipated over the numerous slots eliminating the single wear points associated with other valve types, and increased sealing areas, resulting in much longer seat life.
- Media assisted – The upstream pressure holds the disc in constant contact with the plate. This prevents the sudden, damaging (and noisy) contact which occurs in plug/cage and rotary designs. The constant contact between the disc and plate actually generate a self-lapping effect which results in less friction and tighter shutoff than when the valve leaves the factory in new condition.



Jordan Valve engineers conducted a steam test using 250 psig (17,2 barg) saturated steam. The test was designed so that the valve would fully stroke open and closed each time it was actuated. The pressure drop across the valve was the full 250 psig (17,2 barg). The results were impressive. Our standard Jorcote/Chrome seat combination had less friction than when it was new and the seat leakage was still well below ANSI Class IV limits.

Test: 250 psig pressure drop on saturated steam. Full stroke operation to approximately 70,000 cycles. Standard seat materials.

Result: Tighter shutoff than a brand new valve leaving the factory.

Seat Coatings

Jordan Valve offers several different coatings that can be applied to the stainless steel sliding gate seats for additional wear resistance and greater pressure drop capabilities.

Jorcote is our standard coating material. It is a ceramic based composite material that combines extreme hardness (~Rc 85) with a very low coefficient of friction to provide unsurpassed seat life and stability of control.

Jorcote/Jordanic is a ceramic spray coating that provides hardness equivalent to Stellite 6B, making the seat components extremely resistant to wear and high temperatures. A Jordanic plate combined with a Jorcote disc provides reduced friction properties while being one of our most durable configurations for severe service applications.

Jordan Valve can provide the sliding gate seat in a wide variety of alloy materials such as Hastelloy, Monel, Titanium, Inconel and others. Options such as Teflon coating, hard chrome plating and Jorcote are common solutions employed by Jordan Valve.

Easy to Maintain

When maintenance is needed on a sliding gate valve, the simplistic design makes them easy to perform. Disassembly of the valve is very simple and, since the seats are not pressed or screwed into the valve body, they conveniently lift out. Should your flow requirements change, interchangeable Cv's are available in flow coefficients as low as 0.0008 and as high as 395 (depending on body size).



Size and Weight

As the line sizes increases, so too does the size and weight of the valve. Because of Jordan's short stroke length, a sliding gate valve is typically shorter and lighter weight than a globe-style valve.

When throttling, the control member of a rotary control valve will direct the flow to the sealing area of the seat, causing premature seat leakage or, in flashing or cavitation service, erosion of the wall of the valve body.

The tortuous flow path of a globe style design generates greater turbulence, noise and wear, reducing seat life and compromising control. In flashing or cavitating service, damage to the valve body is common, mitigated only through expensive material upgrades or elaborate trim configurations.

The multi-orifice straight through flow path of the sliding gate reduces turbulence and leads to quieter operation, reduced wear, longer seat life and better control. Combined with the ultra-compact wafer body design, erosion of the seats and valve body (i.e. in cavitation and flashing service) is virtually eliminated. Dramatic cost savings can be realized.

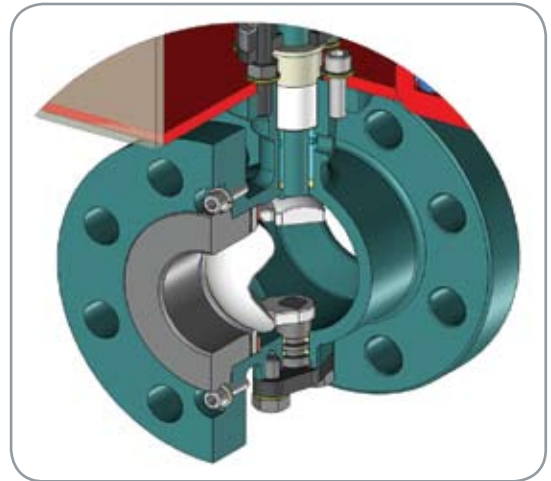

Mark 60 Series Sliding Gate Pressure Regulator

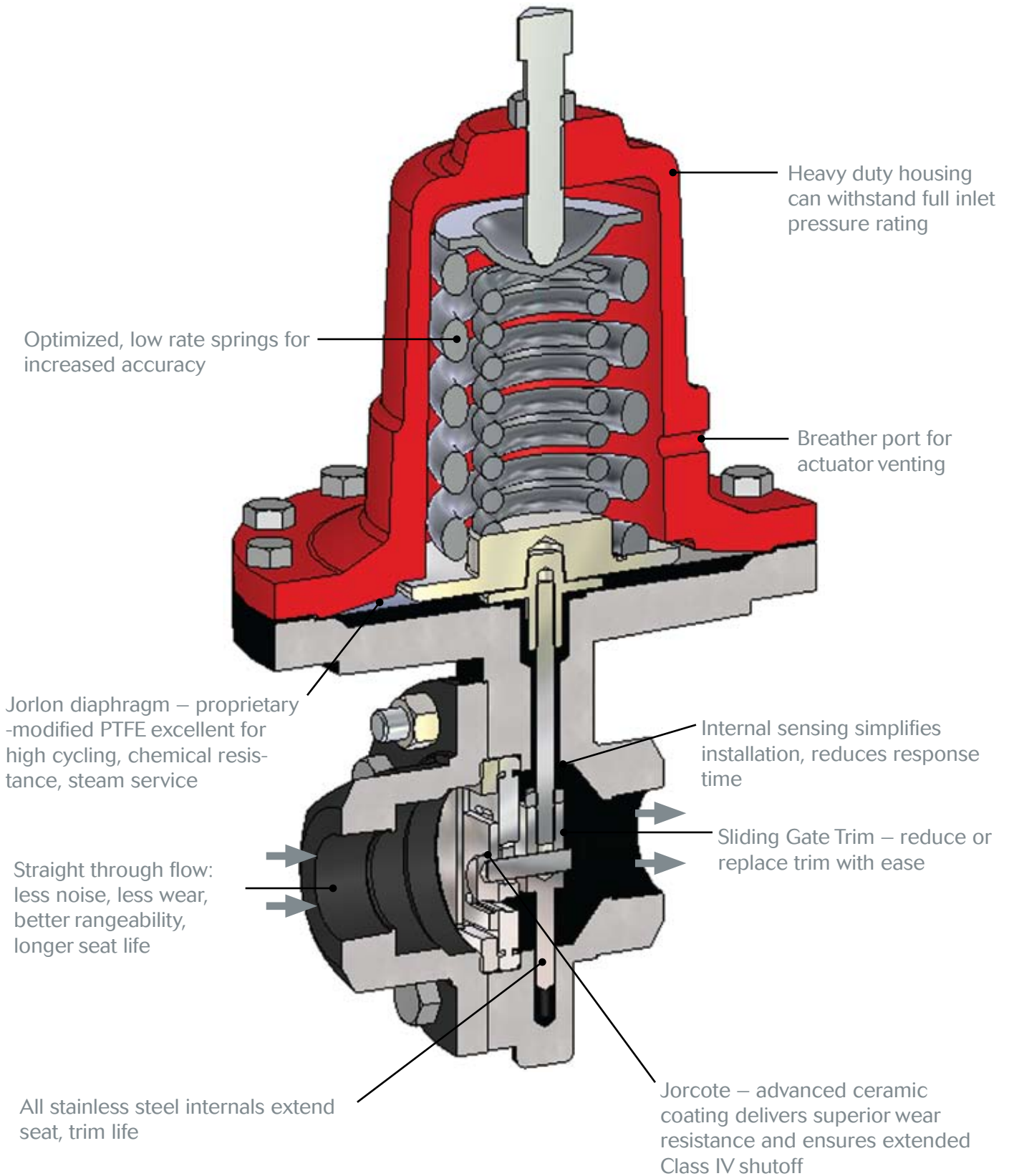

Sliding Gate Regulators

Mark 60/61 Series Self-Operated Pressure Regulators

The Mark 60 handles the broadest range of applications including steam, water, oil, gas, air and chemicals. The Mark 60 features the Sliding Gate seat which combines excellent control and extreme longevity in a compact, lightweight design. The Mark 61 features a larger diaphragm to provide greater sensitivity.



- ➔ Seat: Sliding gate – ANSI Class IV shutoff
- ➔ Sizes: Mk 60: 1/4" – 4" (DN8 – DN100); Mk 61: 1/4" – 3/4" (DN8 – DN20)
- ➔ Body Materials: Ductile Iron, Bronze, Carbon Steel, Stainless Steel, Cast Iron
- ➔ End Connections: Threaded, Flanged, Socket Weld, Butt-Weld
- ➔ Cv (Kv): up to 200 (up to 172)
- ➔ Trim Materials: Stainless Steel, Monel, Hastelloy C, Alloy 20
- ➔ Diaphragm: Stainless Steel, Jorlon, Buna-N, Viton
- ➔ Setpoints: 1 to 450 psi (0,07 to 31,02 bar)

Mark 601/602 Series High-Flow Pressure Regulators

The high-flow MK601 and super high-flow MK602 are used for applications that require a higher Cv rating without using a larger valve. Each valve is standard with Jordan's Sliding Gate seats, which help to reduce the droop commonly associated with high flow regulators.



- ➔ Seat: Sliding gate – ANSI Class IV shutoff
- ➔ Sizes: 1-1/2" through 2" (DN40 through DN50)
- ➔ Body Materials: Ductile Iron, Bronze, Carbon Steel, Stainless Steel
- ➔ End Connections: Threaded, Flanged, Socket Weld, Butt-Weld
- ➔ Cv (Kv): up to 70 (up to 60)
- ➔ Trim Materials: Stainless Steel, Monel, Hastelloy C, Alloy 20
- ➔ Diaphragm: Stainless Steel, Jorlon, Buna-N, Viton
- ➔ Setpoints: 20 to 160 psi (1,4 to 11,0 bar)

Mark 63/64 Series Differential Pressure Regulators

The Mark 63 is designed to maintain a constant differential between the pressure on the discharge side of the regulator and the signal pressure loaded on the diaphragm. The Mark 64 provides the same flow capacity but with less offset. The Mark 64 features a larger effective diaphragm area for greater sensitivity.



- ➔ Seat: Sliding gate – ANSI Class IV shutoff
- ➔ Sizes: MK63: 1/4" – 2" (DN8 – DN50); MK64: 1/4" – 3/4" (DN8 – DN20)
- ➔ Body Materials: Ductile Iron, Bronze, Carbon Steel, Stainless Steel
- ➔ End Connections: Threaded, Flanged, Socket Weld, Butt-Weld
- ➔ Cv (Kv): up to 30 (up to 25,8)
- ➔ Trim Materials: Stainless Steel, Monel, Hastelloy C, Alloy 20
- ➔ Diaphragm: Stainless Steel, Jorlon, Buna-N, Viton
- ➔ Setpoints: 1 to 450 psi (0,07 to 31,02 bar)

Sliding Gate Regulators

Mark 65 Series Vacuum Regulators

Jordan vacuum regulators control very accurately and shutoff tightly to maintain the proper vacuums at pre-determined settings and to regulate vacuums on evaporators, cookers, grinding fixtures, milking machines, altitude chambers and other vacuum systems.

- ➔ Seat: Sliding gate – ANSI Class IV shutoff
- ➔ Sizes: 1/4" through 2" (DN8 through DN50)
- ➔ Body Materials: Ductile Iron, Bronze, Carbon Steel, Stainless Steel
- ➔ End Connections: Threaded, Flanged, Socket Weld, Butt-Weld
- ➔ Cv (Kv): up to 30 (up to 25,8)
- ➔ Trim Materials: Stainless Steel, Monel, Hastelloy C, Alloy 20
- ➔ Diaphragm: Stainless Steel, Jorlon, Buna-N, Viton
- ➔ Setpoints: 1" to 25" Hg vacuum (0,035 to 0,886 kg/cm²)



Mark 66 Series Air Loaded Pressure Regulators

The Mark 66 is one of the most accurate regulators on the market. The dome loaded functionality and the sliding gate seat provide extremely accurate regulation with excellent flow rangeability. Couple the Mark 66 with an extended range I-P for remote control capability.

- ➔ Seat: Sliding gate – ANSI Class IV shutoff
- ➔ Sizes: 1/2" through 6" (DN15 through DN150)
- ➔ Body Materials: Ductile Iron, Bronze, Carbon Steel, Stainless Steel, Cast Iron
- ➔ End Connections: Threaded, Flanged, Socket Weld, Butt-Weld
- ➔ Cv (Kv): up to 395 (up to 339,7)
- ➔ Trim Materials: Stainless Steel, Monel, Hastelloy C, Alloy 20
- ➔ Diaphragm: Stainless Steel, Jorlon, Buna-N, Viton
- ➔ Service: Steam, water, air, gas, oil, chemicals



Mark 67 Series Pilot-Operated Pressure Regulators

The Mark 67 is for critical pressure reducing applications and provides greater accuracy and lower offset than can be achieved with a self-operated regulator. The Sliding Gate seats provides unsurpassed seat and diaphragm life, ease of installation, simplified maintenance and more accurate performance.

- ➔ Seat: Sliding gate – ANSI Class IV shutoff
- ➔ Sizes: 1/2" through 6" (DN15 through DN150)
- ➔ Body Materials: Ductile Iron, Bronze, Carbon Steel, Stainless Steel, Cast Iron
- ➔ End Connections: Threaded, Flanged, Socket Weld, Butt-Weld
- ➔ Cv (Kv): up to 395 (up to 339,7)
- ➔ Trim Materials: Stainless Steel, Monel, Hastelloy C, Alloy 20
- ➔ Diaphragm: Stainless Steel
- ➔ Setpoints: 10 to 200 psi (0,69 to 13,79 bar)



Sliding Gate Regulators

Mark 50/51 Series Self-Operated Back Pressure Regulators

The Mark 50/51 handles the broadest range of applications including steam, water, oil, gas, air and chemicals. Excellent capacity and the sliding gate trim enable the Mark 50 to quickly and accurately regulate upstream pressure, preventing overpressure situations. The Mark 51 features a larger diaphragm.



- ➔ Seat: Sliding gate – ANSI Class IV shutoff
- ➔ Sizes: Mk 50: 1/4" – 4" (DN8 – DN100); Mk 51: 1/4" – 3/4" (DN8 – DN20)
- ➔ Body Materials: Ductile Iron, Bronze, Carbon Steel, Stainless Steel, Cast Iron
- ➔ End Connections: Threaded, Flanged, Socket Weld, Butt-Weld
- ➔ Cv (Kv): up to 200 (up to 172)
- ➔ Trim Materials: Stainless Steel, Monel, Hastelloy C, Alloy 20
- ➔ Diaphragm: Stainless Steel, Jorlon, Buna-N, Viton
- ➔ Setpoints: 0.5 to 450 psi (0,03 to 31,02 bar)

Mark 501/502 Series High-Flow Pressure Regulators

The high-flow MK501 and super high-flow MK502 are used for applications that require a higher Cv rating without going to the next highest line size. Each valve is standard with Jordan's Sliding Gate seats, which helps to reduce the build-up commonly associated with high flow back pressure regulators.



- ➔ Seat: Sliding gate – ANSI Class IV shutoff
- ➔ Sizes: 1-1/2" through 2" (DN40 through DN50)
- ➔ Body Materials: Ductile Iron, Bronze, Carbon Steel, Stainless Steel
- ➔ End Connections: Threaded, Flanged, Socket Weld, Butt-Weld
- ➔ Cv (Kv): up to 70 (up to 60,2)
- ➔ Trim Materials: Stainless Steel, Monel, Hastelloy C, Alloy 20
- ➔ Diaphragm: Stainless Steel, Jorlon, Buna-N, Viton
- ➔ Setpoints: 0.5 to 150 psi (0,03 to 10,3 bar)

Mark 53/54 Series Differential Pressure Regulators

The Mark 53 is designed to maintain inlet pressure at a set differential pressure over the signal pressure loaded on the diaphragm. The Mark 54 provides the same flow capacity as the Mark 53 but with less offset in controlled pressure due to a larger diaphragm.



- ➔ Seat: Sliding gate – ANSI Class IV shutoff
- ➔ Sizes: MK 53: 1/4" – 2" (DN8 – DN50); MK 54: 1/4" – 3/4" (DN8 – DN20)
- ➔ Body Materials: Ductile Iron, Bronze, Carbon Steel, Stainless Steel
- ➔ End Connections: Threaded, Flanged, Socket Weld, Butt-Weld
- ➔ Cv (Kv): up to 30 (up to 25,8)
- ➔ Trim Materials: Stainless Steel, Monel, Hastelloy C, Alloy 20
- ➔ Diaphragm: Stainless Steel, Buna-N, Viton, Jorlon
- ➔ Setpoints: 0.5 to 450 psi (0,03 to 31,02 bar)

Sliding Gate Regulators

Mark 55 Series Vacuum Regulators

The Mark 55 regulators control very accurately and shutoff tightly to maintain the proper vacuums at pre-determined settings and to regulate vacuums on evaporators, cookers, grinding fixtures, milking machines, altitude chambers and other vacuum systems.

- ➔ Seat: Sliding gate – ANSI Class IV shutoff
- ➔ Sizes: 1/4" through 2" (DN8 through DN50)
- ➔ Body Materials: Ductile Iron, Bronze, Carbon Steel, Stainless Steel
- ➔ End Connections: Threaded, Flanged, Socket Weld, Butt-Weld
- ➔ Cv (Kv): up to 30 (up to 25,8)
- ➔ Trim Materials: Stainless Steel, Monel, Hastelloy C, Alloy 20
- ➔ Diaphragm: Stainless Steel, Jorlon, Buna-N, Viton
- ➔ Setpoints: 1" to 25" Hg vacuum (0,035 to 0,886 kg/cm²)



Mark 56 Series Air Loaded Back Pressure Regulators

The Mark 56 is a high accuracy and economic air loaded back pressure regulator that provides regulation from a local or remote station. Jordan JBP regulators and the Mark 12 panel mounting loading stations are ideal for controlling the pressure load to the top of the diaphragm.

- ➔ Seat: Sliding gate – ANSI Class IV shutoff
- ➔ Sizes: 1/2" through 6" (DN15 through DN150)
- ➔ Body Materials: Ductile Iron, Bronze, Carbon Steel, Stainless Steel, Cast Iron
- ➔ End Connections: Threaded, Flanged, Socket Weld, Butt-Weld
- ➔ Cv (Kv): up to 395 (up to 339,7)
- ➔ Trim Materials: Stainless Steel, Monel, Hastelloy C, Alloy 20
- ➔ Diaphragm: Stainless Steel, Jorlon, Buna-N, Viton
- ➔ Service: Steam, water, air, gas, oil chemicals



Mark 57 Series Pilot-Operated Back Pressure Regulators

The Mark 57 piloted operated back pressure regulator is designed to accurately control pressure to 100% of its rated flow capacity with only a small deviation from setpoint. The Mark 57 provides accuracy that approaches that of controller-operated valves.

- ➔ Seat: Sliding gate – ANSI Class IV shutoff
- ➔ Sizes: 1/2" through 6" (DN15 through DN150)
- ➔ Body Materials: Ductile Iron, Bronze, Carbon Steel, Stainless Steel, Cast Iron
- ➔ End Connections: Threaded, Flanged, Socket Weld, Butt-Weld
- ➔ Cv (Kv): up to 395 (up to 339,7)
- ➔ Trim Materials: Stainless Steel, Monel, Hastelloy C, Alloy 20
- ➔ Diaphragm: Stainless Steel
- ➔ Setpoints: 10 to 200 psi (0,69 to 13,79 bar)



Globe and Cage Style Regulators

Mark 68G Series Pressure Regulators

The Mark 68G offers high capacity, accurate regulation, and easy servicing, making it the ideal choice for your industrial-grade pressure reducing applications. The diaphragm can be easily accessed from the top allowing some repairs to be conducted without removing the valve from the line.



- ➔ Seat: Plug – Buna-N, Viton, Hardened 17-4 pH Stainless Steel
- ➔ Sizes: 1/4" through 2" (DN8 through DN50)
- ➔ Body Materials: Ductile Iron, Bronze, Carbon Steel, Stainless Steel
- ➔ End Connections: Threaded, Flanged, Socket Weld
- ➔ Cv (Kv): up to 19 (up to 16,3)
- ➔ Trim Material: Stainless Steel
- ➔ Diaphragm: Stainless Steel, Jorlon, Buna-N/Nylon, Viton/Nomex
- ➔ Shutoff: ANSI Class IV (hard seat); ANSI Class VI (soft seat)

Mark 686 Series Air-Loaded Cage Trim Pressure Regulators

The Mark 686 features air-loading, high capacities, accurate regulation and easy servicing, making it an exceptional choice for your pressure regulating applications. The diaphragm is easily accessible from the top, allowing maintenance without removing the valve from the line.

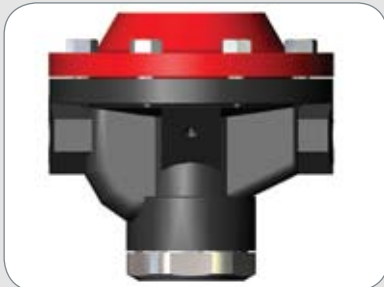

- ➔ Seat: Plug – Buna-N, Viton, Hardened 17-4 pH Stainless Steel
- ➔ Sizes: 1/4" through 2" (DN8 through DN50)
- ➔ Body Materials: Ductile Iron, Bronze, Carbon Steel, Stainless Steel
- ➔ End Connections: Threaded, Flanged, Socket Weld
- ➔ Cv (Kv): up to 19 (up to 16,3)
- ➔ Cage Materials: Stainless Steel
- ➔ Diaphragm: Stainless Steel, Jorlon, Buna-N/Nylon, Viton/Nomex
- ➔ Shutoff: ANSI Class IV (hard seat); ANSI Class VI (soft seat)

Mark 58 Series Cage Trim Pressure Regulator

The Mark 58 features three ports: a bypass outlet on the bottom, and two side ports which are directly connected to serve as dual inlet and outlet for through-flow



- ➔ Seat: Plug – Buna-N, Viton, EPDM, 17-4 PH Stainless Steel
- ➔ Sizes: 1/4" through 2" (DN8 through DN50)
- ➔ Body Materials: Ductile Iron, Bronze, Carbon Steel, Stainless Steel
- ➔ End Connections: Threaded, Flanged, Socket Weld
- ➔ Cv (Kv): up to 32.4 (up to 27,86)
- ➔ Cage Materials: Stainless Steel
- ➔ Diaphragm: Stainless Steel, Jorlon, Buna-N/Nylon, Viton/Nomex
- ➔ Shutoff: ANSI Class IV (hard seat); ANSI Class VI (soft seat)

Low Pressure Regulators For Tank Blanketing and Venting

Mark 508/608 Series Low Flow Tank Blanketing Regulators (3/4" – 1-1/4")

The Mark 508/608 Series are low flow, low pressure regulators designed to maintain precise gas blanket pressure of storage tanks. Working together, the MK608 and 508 can help reduce nitrogen usage, preserve storage medium, increase safety and protect the environment.

- ➔ ANSI Class VI shutoff
- ➔ Sizes: 3/4" through 1-1/4" (DN20 through DN32)
- ➔ Body Materials: Carbon Steel, Stainless Steel, Ductile Iron
- ➔ End Connections: Threaded, Flanged, Socket Weld
- ➔ Trim Materials: Stainless Steel
- ➔ Plug: Buna-N, Viton
- ➔ Setpoints: 1" w.c. – 3.5 psi
- ➔ Maximum Inlet Pressure: 150 psi (10,3 bar)



Mark 508/608 Series Medium Flow Tank Blanketing Regulator (1-1/2" – 2")

The Mark 508/608 medium flow tank blanketing regulators feature a large diaphragm area for superb sensitivity and accuracy. They are for use on large tank blanketing applications or other low back pressure applications.

- ➔ ANSI Class VI Shutoff
- ➔ Sizes: 1-1/2" – 2" (DN40 – DN50)
- ➔ Body Materials: Bronze, Carbon Steel, Stainless Steel
- ➔ End Connections: Threaded, Flanged, Socket Weld
- ➔ Trim Materials: Stainless Steel
- ➔ Diaphragm: Viton, Buna-N, EPDM (with polyester reinforcement)
- ➔ Cv (Kv): up to 23 (up to 20)
- ➔ Maximum Pressure Drop: 25 psig (1,7 bar)



Mark 518/618 Series High Flow Tank Blanketing Regulators

The Mark 518/618 Series are spring loaded low pressure regulators specifically designed for tank blanketing applications. The balanced trim, large diaphragm design provides high flow rates and excellent regulation without a pilot

- ➔ ANSI Class VI Shutoff
- ➔ Sizes: 1", 2" 4" (DN25, DN50, DN100)
- ➔ Body Materials: 316 Stainless Steel or Hastelloy C
- ➔ End Connections: Threaded, Flanged
- ➔ Cv (Kv): up to 81 (up to 70)
- ➔ Trim Materials: 316 Stainless Steel or Hastelloy C
- ➔ Diaphragm: PTFE, Viton`
- ➔ Setpoints: 1" W.c. – 7.5 psi



High Pressure Regulators

Mark 6800HP Series High Pressure Regulating Valves

A line of self-operated pressure regulating valves for use on high pressure industrial gas and liquid services to 4,000 psi (275,8 bar). The 6800HP features a balanced piston design for excellent stability even in high pressure drop situations.



- ➔ Seat: Stellite, Vespel, Teflon®
- ➔ Sizes: 1/2" through 1" (DN15 through DN25)
- ➔ Body Materials: 316L Stainless Steel
- ➔ End Connections: Threaded, Socket Weld, Flanged
- ➔ Cv (Kv): up to 2.5 (up to 2,2)
- ➔ Shutoff: ANSI Class III, Class V or Class VI
- ➔ O-Ring Materials: Buna, Viton, EPDM
- ➔ Setpoints: 250 to 3000 psi

Mark 5800HP Series High Back Pressure Regulator

The Mark 5800HP Series is a high pressure, back pressure regulator designed to maintain upstream pressure of gases and liquids. As a compact, lightweight product, it is well suited for applications where space and weight are at a premium.



- ➔ Seat: Teflon (standard) Nylon, PEEK, Delrin (optional)
- ➔ Sizes: 1/2" through 1" (DN15 through DN25)
- ➔ Body Materials: 316L Stainless Steel
- ➔ End Connections: Threaded, Socket Weld, Flanged
- ➔ Cv (Kv): up to 1.0 (up to 0,86)
- ➔ Shutoff: ANSI Class VI
- ➔ O-Ring Materials: Buna-N, Viton, EPDM
- ➔ Setpoints: 400 - 2500 psi

J Series High Pressure Regulators

The J Series has the ability to handle high inlet pressures and large delta P's, offering low pressure set-points. These valves are typically used in research and sampling systems for corrosive and specialty gases and liquids.



- ➔ Seat: Kel-F, Polyimide, Ceramic-filled Teflon
- ➔ Sizes: JPR: 1/4" – 3/8" (DN8 – DN10); JHR: 3/8" – 1/2" (DN10 – DN15)
- ➔ Body Materials: Stainless Steel, Chrome, Brass, Hastelloy, Monel, Titanium
- ➔ End Connections: FNPT, Tube End
- ➔ Cv (Kv): JPR: 0.06 (0,05), 0.02 (0,017), 0.2 (0,17); JHR: 0.60 (0,52)
- ➔ Supply Pressure Effect: JPR: 0.5/100 psig (0,03/7,0 barg)
- ➔ Supply Pressure Effect: JHR: 2/100 psig (0,14/9 barg)
- ➔ Internal Volume: JPR: 6.9 cc; JHR: 10 cc

Mark 75 Series Sliding Gate Control Valve

All the benefits of the time-tested sliding gate design, but in a lighter-weight design

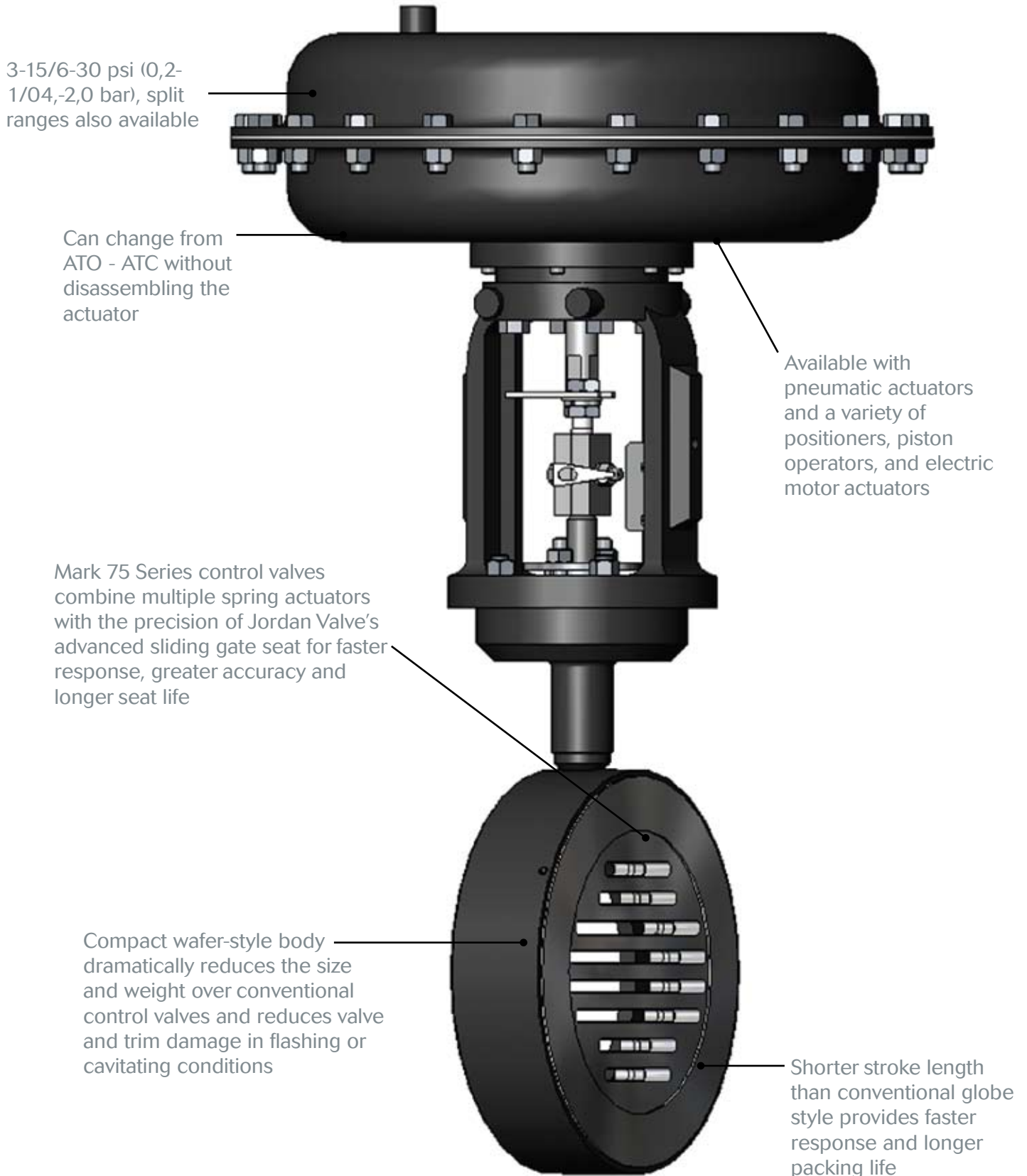

Sliding Gate Control Valves

Mark 75 Series Wafer Style Sliding Gate Control Valves

With all the benefits of the time-tested Sliding Gate design, but in a lighter weight, compact wafer-style body, the Mark 75 dramatically reduces the size and weight of conventional control valves.



- ➔ Sizes: 1" – 6" (DN25 – DN150)
- ➔ Body Materials: 316 Stainless Steel, Carbon Steel
- ➔ Seat Materials: Jorcote/316SS standard; Jorcote/Jordanic/316SS opt.
- ➔ Cv (Kv): up to 400 (up to 345)
- ➔ Shutoff: ANSI Class IV
- ➔ Turndown: up to 100:1
- ➔ Action: Direct (ATC) or Reverse (ATO)
- ➔ Ranges: 3-15 psi, 6-30 psi or split ranges (0,2-1,0 bar, 0,4-2,1 bar)

Mark 70 Series Sliding Gate Control Valves

The Mark 70 Series is a line of pneumatically-operated diaphragm control valves that combine multiple spring actuators with the precision of Jordan Valve's advanced sliding gate seat for closer control and greater accuracy. Above a 2" the Mark 70 is a Mark 711.



- ➔ Sizes: 1/4" – 2" (DN8 – DN50)
- ➔ Body Materials: Ductile Iron, Bronze, Carbon Steel, Stainless Steel
- ➔ Seat Materials: Jorcote on SST standard; Jorcote/Jordanic on SST
- ➔ Cv (Kv): up to 30 (up to 26)
- ➔ Shutoff: ANSI Class IV
- ➔ Turndown: 100:1
- ➔ Action: Direct (ATC) or Reverse (ATO)
- ➔ Ranges: 3-15 psi, 6-30 psi or split ranges (0,2-1,0 bar, 0,4-2,1 bar)

Mark 701/702 Series High Flow & Super High Flow Control Valves

The Mark 701/702 high flow and super high-flow sliding gate control valves provide shorter stroke than a globe or plug style valve, straight through flow and ease of maintenance



- ➔ Sizes: 1/2" – 2" (DN15 – DN50)
- ➔ Body Materials: Ductile Iron, Bronze, Carbon Steel, Stainless Steel
- ➔ Seat Materials: Jorcote on SST standard; Jorcote/Jordanic on SST
- ➔ Cv (Kv): up to 70.0 (up to 60,3)
- ➔ Shutoff: ANSI Class IV
- ➔ Turndown: 100:1
- ➔ Action: Direct (ATC) or Reverse (ATO)
- ➔ Ranges: 3-15 psi, 6-30 psi or split ranges (0,2-1,0 bar, 0,4-2,1 bar)

Control Valves

Mark 74 Series Bellows Seal Control Valve

The Mark 74 provides exceptional bellows life with a valve stroke that is just a fraction of that of other rising stem valves. This means Jordan Valve can use a smaller formed bellows that has minimal movement during operation.

- ➔ Sizes: 1/4" – 2" (DN8 – DN50)
- ➔ Body Materials: Ductile Iron, Bronze, Carbon Steel, Stainless Steel
- ➔ Seat Materials: Jorcote/316SS standard; Jorcote/Jordanic/316SS opt.
- ➔ Cv (Kv): up to 30 (up to 10,3)
- ➔ Shutoff: ANSI Class IV
- ➔ Turndown: 100:1
- ➔ Action: Direct (ATC) or Reverse (ATO)
- ➔ Ranges: 3-15 psi, 6-30 psi or split ranges (0,2-1,0 bar, 0,4-2,1 bar)



Mark 37 Series Final Control Element Valve

The Mark 37 is a motor-operated control valve that combines a state-of-the-art electronic linear actuator with the exceptional performance of Jordan's sliding gate seat design. The result is a superior degree of accuracy that makes it ideal for use as the final control element in distributed process control systems.

- ➔ Seat Type: Sliding Gate – ANSI Class IV shutoff
- ➔ Sizes: 1/4" – 6" (DN8 – DN150)
- ➔ Body Materials: Ductile Iron, Bronze, Carbon Steel, Stainless Steel, Cast Iron
- ➔ End Connections: Threaded, Flanged, Socket Weld, Butt-Weld
- ➔ Cv (Kv): up to 395 (up to 339,7)
- ➔ Trim Materials: Stainless Steel, Monel, Hastelloy C, Alloy 20
- ➔ Seat Materials: Jorcote, Jorcote/Jordanic
- ➔ Command Signals: Current or voltage command, on/off

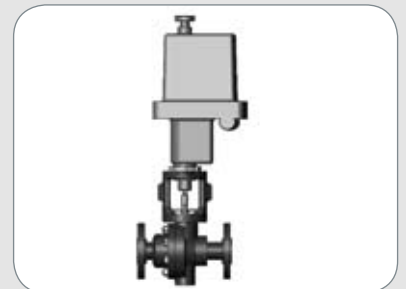

Mark 33 Series Electric Motor Control Valves

The Mark 33 is a motor operated valve featuring the Jordan sliding gate seat and heavy-duty industrial motors for proportional (resistance), on-off, or 4-20mA electronic format

- ➔ Seat: Sliding Gate – ANSI Class IV shutoff
- ➔ Sizes: 1/4" – 2" (DN8 – DN50)
- ➔ Body Materials: Ductile Iron, Bronze, Carbon Steel, Stainless Steel
- ➔ End Connections: Threaded, Flanged, Socket Weld, Butt-Weld
- ➔ Cv (Kv): up to 30 (up to 25,9)
- ➔ Trim Materials: Stainless Steel, Monel, Hastelloy C, Alloy 20
- ➔ Seat Materials: Jorcote, Jorcote/Jordanic
- ➔ Command Signals: Proportional (resistance), on/off, milliamp, or 2-10 VDC

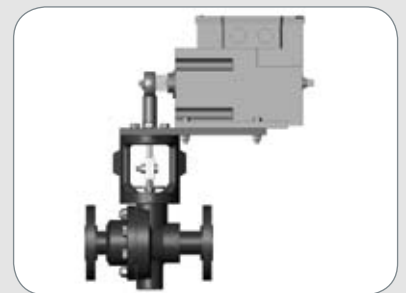

Control Valves

Mark 78 Series Globe Style Control Valves

The Mark 78 pneumatic control valve is designed for accurate performance and simplified maintenance. This versatile product can be used on a variety of applications, including viscous/corrosive liquids, process gases or utility steam in process or utility service.



- ➔ Seat Type: Globe – ANSI Class IV or VI shutoff
- ➔ Sizes: 1/2" – 4" (DN15 – DN100)
- ➔ End Connections: Threaded, Flanged, Socket Weld, Butt-Weld
- ➔ Body Materials: Bronze, Carbon Steel, Stainless Steel
- ➔ Cv (Kv): up to 200 (up to 172)
- ➔ Trim Materials: Stainless Steel, Monel, Hastelloy C, Alloy 20
- ➔ Seat: ANSI Class IV (Hard Seat); ANSI Class VI Teflon (Soft Seat)
- ➔ Control Ranges: 3-15 psi, 6-30 psi or split ranges (0,2-1,0 bar, 0,4-2,1 bar)

V1C Series Cage-Guided Control Valve

The V1C cage-guided balanced trim control valve offers high pressure and tight shutoff with the use of standard spring/diaphragm actuators. The V1C contains a cage that is characterized in order to allow equal percentage and linear flow characteristics.



- ➔ Seat Type: Cage – ANSI Class III, IV or VI
- ➔ Sizes: 1-1/2" – 6" (DN40 – DN150)
- ➔ Body Materials: Carbon Steel, Stainless Steel
- ➔ End Connections: Threaded, Socket Weld or Flanged
- ➔ Cv (Kv): up to 400 (up to 344)
- ➔ Trim Materials: Stainless Steel
- ➔ Bonnet Types: Plain, Extended, Bellows Seal
- ➔ Control Ranges: 3-15 psi, 6-30 psi or split ranges (0,2-1,0 bar, 0,4-2,1 bar)

Mark 2000 Series Angle Seat On/Off Control Valves

The Mark 2000 is an externally piloted angle-seat valve with self-adjusting packing gland, intermediate relief and wiper. The angle-seat construction of the body makes possible extremely high flow rates, particularly in comparison to conventional globe valves.



- ➔ Seat: PTFE
- ➔ Sizes: 1/2" – 2" (DN15 – DN50)
- ➔ Body Materials: 316 SST
- ➔ End Connections: Threaded (NPT)
- ➔ Pressure Range: 0 – 362 psi, max (0 – 25 bar)
- ➔ Trim Materials: 304 SST
- ➔ Packing Materials: Spring loaded, PTFE-V Rings
- ➔ Solenoid Options: 125VAC or 24 VDC

Temperature Regulators

Mark 80 Series Self-Operated Temperature Regulators

The Mark 80 Series is completely self-operated and requires no external power source or other expensive instrumentation to operate the valve.

- ➔ Seat Type: Sliding Gate – ANSI Class IV shutoff
- ➔ Sizes: 1/4" – 2" (DN8 – DN50)
- ➔ End Connections: Threaded, Flanged, Socket Weld, Butt-Weld
- ➔ Body Materials: Ductile Iron, Bronze, Carbon Steel, Stainless Steel
- ➔ Cv (Kv): up to 30 (up to 25,8)
- ➔ Trim Materials: Stainless Steel, Monel, Hastelloy C, Alloy 20
- ➔ Seat Materials: Jorcote, Jorcote/Jordanic
- ➔ Thermal System: Seal-welded actuator (SWA) with capillary and bulb



Mark 801/802 Series Self-Operated Temperature Regulators

The Mark 801/802 Series is completely self-operated and requires no external power source or other expensive instrumentation to operate the valve. The Mark 801/802 Series are high-flow and super high-flow versions of our Mark 80 Series temperature regulators.

- ➔ Seat Type: Sliding Gate – ANSI Class IV shutoff
- ➔ Sizes: 1/2" – 2" (DN15 – DN50)
- ➔ End Connections: Threaded, Flanged, Socket Weld, Butt-Weld
- ➔ Body Materials: Ductile Iron, Bronze, Carbon Steel, Stainless Steel
- ➔ Cv (Kv): up to 70 (up to 60,2)
- ➔ Trim Materials: Stainless Steel, Monel, Hastelloy C, Alloy 20
- ➔ Seat Materials: Jorcote, Jorcote/Jordanic
- ➔ Thermal System: Seal-welded actuator (SWA) with capillary and bulb



Mark 85 Series "Controlled Failure" Temperature Regulator

The Mark 85 is a self-operated temperature regulator with controlled failure option which allows you to predetermine the position of the valve in the event of a thermal system failure. The Mark 85 is designed to fail closed on heating applications and to fail open on cooling applications.

- ➔ Seat Type: Sliding Gate – ANSI Class IV
- ➔ Sizes: 1/4" – 3/4" (DN8 – DN20)
- ➔ Body Materials: Ductile Iron, Bronze, Carbon Steel, Stainless Steel
- ➔ End Connections: Threaded, Flanged, Socket Weld, Butt-Weld
- ➔ Cv (Kv): up to 4.4 (up to 3,8)
- ➔ Trim Materials: Stainless Steel, Monel, Hastelloy C, Alloy 20
- ➔ Seat Materials: Jorcote, Jorcote/Jordanic
- ➔ Thermal System: Bolted Cast Iron Actuator with capillary and bulb

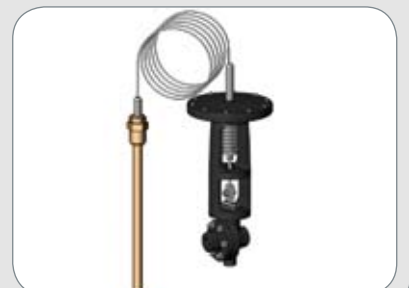

Temperature Regulators

Mark 86 Series Steam Tracing Regulators

The Mark 86 ambitemp regulator is designed to control steam tracing lines based on ambient temperatures. The MK86 allows steam to flow through the tracer lines only when it is needed, and remains closed when the ambient temperature rises above the predetermined setpoint.



- ➔ Seat Type: Sliding Gate – ANSI Class IV shutoff
- ➔ Sizes: 1/2" – 2" (DN15 – DN50)
- ➔ End Connections: Threaded, Flanged, Socket Weld, Butt-Weld
- ➔ Body Materials: Ductile Iron, Bronze, Carbon Steel, Stainless Steel
- ➔ Cv (Kv): up to 30 (up to 25,8)
- ➔ Trim Materials: Stainless Steel, Monel, Hastelloy C, Alloy 20
- ➔ Seat Materials: Jorcote, Jorcote/Jordanic
- ➔ Thermal System: Seal-welded actuator (SWA)

Mark 87 Series External Piloted Temperature Regulators

The Mark 87 piloted temperature regulator is the Sliding Gate valve engineered to provide wide rangeability, and greater accuracy, for a variety of temperature control applications. Designed with the same technology as the Mark 80, the Mark 87 is a piloted temperature regulator that offers quality and performance.



- ➔ Seat Type: Sliding Gate – ANSI Class IV shutoff
- ➔ Sizes: 1/2" – 6" (DN15 – DN150)
- ➔ End Connections: Threaded, Flanged, Socket Weld, Butt-Weld
- ➔ Body Materials: Ductile Iron, Bronze, Carbon Steel, Stainless Steel, Cast Iron
- ➔ Cv (Kv): up to 395 (up to 339,7)
- ➔ Trim Materials: Stainless Steel, Monel, Hastelloy C, Alloy 20
- ➔ Seat Materials: Jorcote, Jorcote/Jordanic
- ➔ Thermal System: Seal-welded actuator (SWA) with capillary and bulb

Mark 89 Series Three-Way Temperature Regulators

The Mark 89 is used for diverting service and is ideal for bypassing fluids around coolers or filters. In this configuration, there is one inlet and two outlets. As one outlet closes, the other outlet opens, diverting flow from one channel to the other. The Mark MK89MX is ideal for mixing service.



- ➔ Seat Type: Sliding Gate – ANSI Class IV Shutoff
- ➔ Sizes: 1-1/2" – 2" (DN40 – DN50)
- ➔ Body Materials: Carbon Steel, Stainless Steel
- ➔ End Connections: Threaded, Socket Weld, or Flanged
- ➔ Cv (Kv): up to 30 (up to 25,8)
- ➔ Trim Materials: Stainless Steel, Monel, Hastelloy C, Alloy 20
- ➔ Seat Materials: Jorcote, Jorcote/Jordanic
- ➔ Thermal System: Seal-welded actuator (SWA) with Capillary and bulb

Mark 708 Series Low Flow Valves

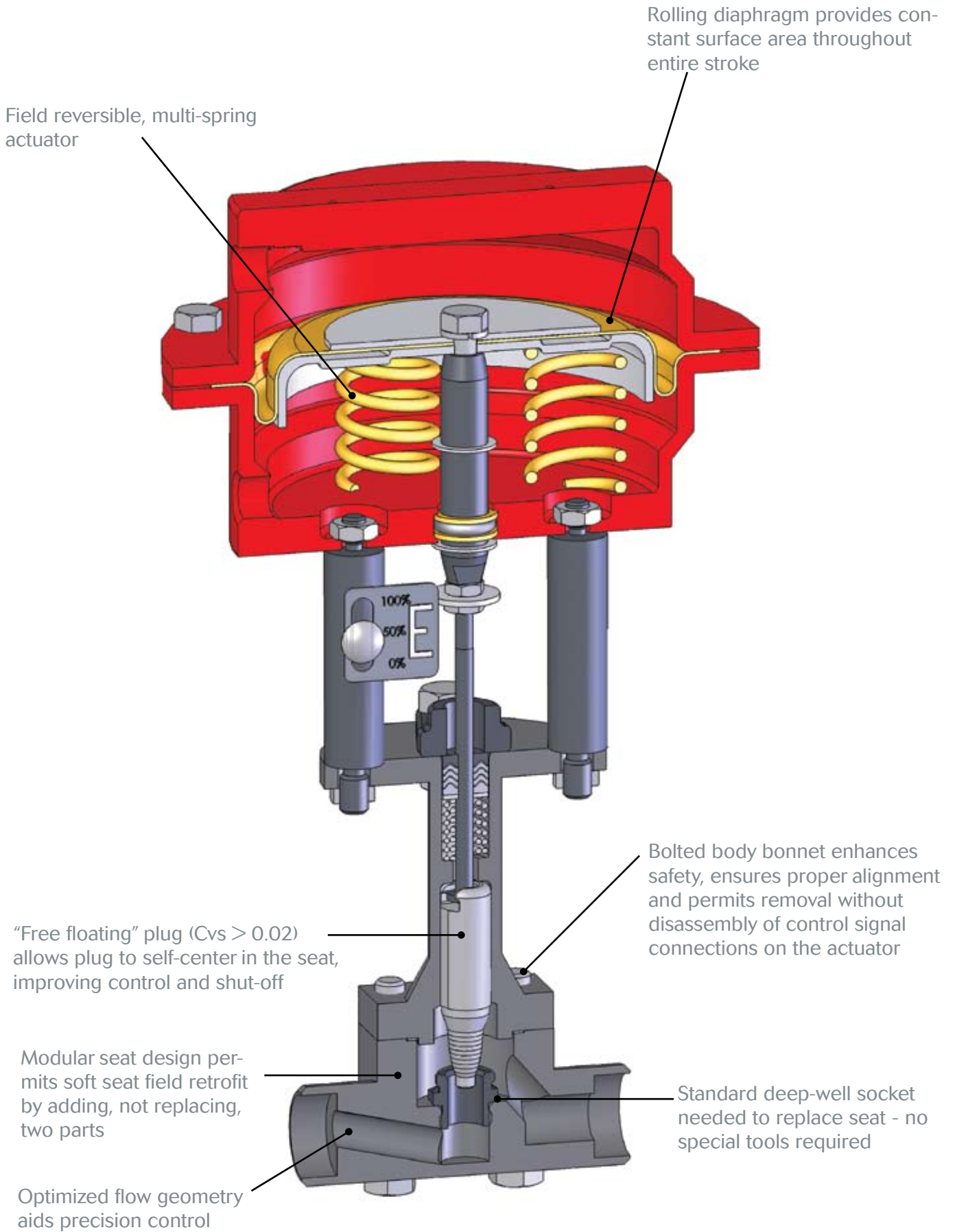

Low Flow Valves

Mark 708 Series Fractional Flow Control Valves

The Mark 708 provides the most accurate control available for fractional flow services, whether for pilot plant installations, test stands, R & D facilities, or for specialized processes such as dosing, injection, and venting applications.



- ➔ Seat Type: Globe/Needle – Class III, IV or VI
- ➔ Sizes: 1/4" – 3/4" (DN8 – DN20)
- ➔ End Connections: Threaded, Socket Weld, Integral Tube, Flanged
- ➔ Body Materials: Carbon Steel, Stainless Steel, Hastelloy, others
- ➔ Trim Materials: Stainless Steel, Monel, Hastelloy C, Alloy 20, others
- ➔ Control Ranges: 3-15 psi, 6-30 psi or split ranges (0,2-1,0 bar, 0,4-2,1 bar)
- ➔ Cv (Kv): up to 4.0 (up to 3,4)
- ➔ Service: Steam, air, gas, oil, water, chemicals

Mark 708QC Series Quick Change Trim Fractional Flow Control Valves

The quick change option allows change of the trim without removing the valve body from the process line or disturbing the actuator setting.



- ➔ Seat Type: Globe/Needle – Class III, IV or VI
- ➔ Sizes: 1/4" – 3/4" (DN8– DN20)
- ➔ End Connections: Threaded, Socket Weld, Integral Tube, Flanged
- ➔ Body Materials: Carbon Steel, Stainless Steel, Hastelloy C, others
- ➔ Trim Materials: Stainless Steel, Monel, Hastelloy C, Alloy 20, others
- ➔ Control Ranges: 3-15 psi, 6-30 psi or split ranges (0,2-1,0 bar, 0,4-2,1 bar)
- ➔ Cv (Kv): up to 4.0 (up to 3,4)
- ➔ Service: Steam, air, gas, oil, water, chemicals

Mark 708MV Series Electronic Fractional Flow Control Valves

The Mark 708MV is a premiere control valve for applications involving chemical injection, dosing, pilot plants and research labs. It offers several advantages including extreme accuracy, high turndown ratios, and repeatability.

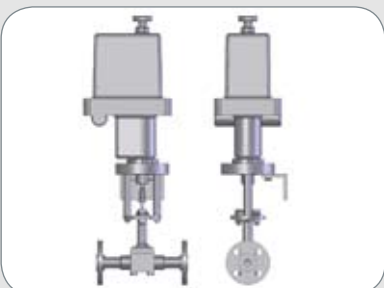

- ➔ Seat Type: Globe/Needle – Class III, IV or VI
- ➔ Sizes: 1/4" – 3/4" (DN8 – DN20)
- ➔ End Connections: Threaded, Socket Weld, Integral Tube, Flanged
- ➔ Body Materials: Carbon Steel, Stainless Steel, Hastelloy C, others
- ➔ Trim Materials: Stainless Steel, Monel, Hastelloy C, Alloy 20, others
- ➔ Command Signals: Current or Voltage Command, On/Off
- ➔ Cv (Kv): up to 4.0 (up to 3,4)
- ➔ Approvals: Nema 4x/7/9, CE mark and ATEX approvals available

Low Flow Valves

Mark 708 Series Bellows Stem Seal Fractional Flow Control Valves

The Mark 708 bellows stem seals eliminate fugitive emissions by surrounding the valve stem with a pressure-tight barrier, isolating the stem from the process fluid and preventing leakage to the atmosphere.

- ➔ Seat Type: Globe/Needle – Class III, IV or VI
- ➔ Sizes: 1/4" – 3/4" (DN8 – DN20)
- ➔ Body Materials: Carbon Steel, Stainless Steel, Hastelloy C, others
- ➔ End Connections: Threaded, Socket Weld, Integral Tube, Flanged
- ➔ Trim Materials: Stainless Steel, Hastelloy C
- ➔ Control Ranges: 3-15 psi, 6-30 psi or split ranges (0,2-1,0 bar, 0,4-2,1 bar)
- ➔ Cv (Kv): up to 4.0 (up to 3,4)
- ➔ Service: steam, air, gas, chemicals, oil, water



Mark 708 Series Cryogenic Bonnet Fractional Flow Control Valve

The Mark 708 for cryogenic service features a 9" bonnet extension that provides protection for the packing and actuator by preventing ice build-up which can interfere with the movement of the valve stem and affect valve performance.

- ➔ Seat Type: Globe/Needle – Class III, IV or VI
- ➔ Sizes: 1/4" – 3/4" (DN8 – DN20)
- ➔ Body Materials: Stainless Steel
- ➔ End Connections: Threaded, Socket Weld, Integral Tube Ends, Flanged
- ➔ Trim Materials: 17-4 plug, 316SS stem and seat
- ➔ Control Ranges: 3-15 psi, 6-30 psi or split ranges (0,2-1,0 bar, 0,4-2,1 bar)
- ➔ Cv (Kv): up to 4.0 (up to 3,4)



Mark 709 Series Three Way Fractional Flow Control Valves

The Mark 709 is a lightweight control valve for use as a mixing valve in low flow process applications. Featuring a three-way body design, it is constructed with two inlets to blend two separate flow streams into a common outlet, creating a third fluid.

- ➔ Seat Type: Globe/Need – Class III, IV or VI
- ➔ Sizes: 1/2" & 3/4" (DN15 & DN20)
- ➔ Body Materials: Carbon Steel, Stainless Steel, Hastelloy C, others
- ➔ End Connections: Threaded, Socket Weld, Flanged
- ➔ Trim Materials: Stainless Steel, Hastelloy C, others
- ➔ Control Ranges: 3-15 psi, 6-30 psi or split ranges (0,2-1,0 bar, 0,4-2,1 bar)
- ➔ Cv (Kv): up to 4.0 (up to 3,4)
- ➔ Service: Air, gas, chemicals, oil, water



Fractional Flow Valves

Mark 8000 Series Fractional Flow Control Valves

The Mark 8000 is a group of heavy-duty control valves specifically designed for process applications requiring full flow or fractional flow control. The valve subassembly is manufactured completely from barstock.



- ➔ Seat Type: Globe or Angle – Class III, IV or VI
- ➔ Sizes: 1/2" – 2" (DN15 – DN50)
- ➔ End Connections: Threaded, Flanged, Socket Weld, Butt-Weld
- ➔ Body Materials: Carbon Steel, Stainless Steel, Brass, Hastelloy C, others
- ➔ Trim Materials: Stainless Steel, Monel, Hastelloy C, others
- ➔ Diaphragm Materials: Buna-N/Nylon
- ➔ Ranges: 3-15 psi, 6-30 psi or split ranges (0,2-1,0 bar, 0,4-2,1 bar)

Mark 8000 Series Bellows Stem Seal

Bellows stem seals eliminate fugitive emissions by surrounding the valve stem with a pressure-tight barrier, isolating the stem from the process fluid and preventing leakage to the atmosphere. For an extra measure of protection, the bellows stem seal option provides a back-up seal of Teflon, braided or Graphite/Grafoil Packing.



- ➔ Seat Type: Globe – Class III, IV or VI
- ➔ Sizes: 1/2" – 3/4" (DN15– DN20)
- ➔ End Connections: Threaded, Flanged, Socket Weld, Butt-Weld
- ➔ Body Materials: Carbon Steel, Stainless Steel, Brass, Hastelloy C, others
- ➔ Trim Materials: Stainless Steel, Hastelloy C
- ➔ Diaphragm Materials: Buna-N/Nylon
- ➔ Ranges: 3-15 psi, 6-30 psi or split ranges (0,2-1,0 bar, 0,4-2,1 bar)

Mark 8000 Series Cryogenic Option

The cryogenic option offers a bonnet extension that provides protection for the packing and actuator by preventing the formation and build-up of ice, which can interfere with movement of the valve stem and affect valve performance and control.



- ➔ Seat Type: Globe – Class III, IV or VI
- ➔ Sizes: 1/2" – 2" (DN15 – DN50)
- ➔ End Connections: Threaded, Flanged, Socket Weld, Butt-Weld
- ➔ Body Materials: Carbon Steel, Stainless Steel, Brass, Hastelloy C, others
- ➔ Trim Materials: Stainless Steel, Monel, Hastelloy C, others
- ➔ Diaphragm Materials: Buna-N/Nylon
- ➔ Ranges: 3-15 psi, 6-30 psi or split ranges (0,2-1,0 bar, 0,4-2,1 bar)

Fractional Flow Valves

Mark 8000 Series Three Way Body

The three way Mark 8000 can be specified for use on mixing or diverting services. It is recommended for use when service or environment conditions may be too harsh for traditional three way control valves.

- ➔ Seat Type: Globe – Class III, IV or VI
- ➔ Sizes: 1/2" – 1" (DN15 – DN25)
- ➔ Body Materials: Carbon Steel, Stainless Steel, Hastelloy C, others
- ➔ End Connections: Threaded, Flanged, Socket Weld
- ➔ Trim Materials: Stainless Steel, Hastelloy C, others
- ➔ Diaphragm Materials: Buna-N/Nylon
- ➔ Ranges: 3-15 psi, 6-30 psi or split ranges (0,2-1,0 bar, 0,4-2,1 bar)



Mark 8000 Series with Thermoplastic Materials

The Mark 8000 can be manufactured in PCV, or Kynar for applications where thermoplastics offer a better solution over alloy materials, particularly in processes using extremely aggressive materials.

- ➔ Seat Type: Globe – Class VI
- ➔ Sizes: 1/2" – 2" (DN15 – DN50)
- ➔ Body Materials: PVC, Kynar
- ➔ End Connections: Threaded, Bolt-Thru Flanged
- ➔ Trim Materials: PVC, , Kynar
- ➔ Diaphragm Materials: Buna-N/Nylon
- ➔ Ranges: 3-15 psi, 6-30 psi or split ranges (0,2-1,0 bar, 0,4-2,1 bar)



Please refer to the Steriflow Condensed Catalog for information relating to our complete line of sanitary pressure regulators, back pressure regulators, control valves, ball valves, steam traps and high purity pressure regulators.

To learn more about Jordan Valve products and to find the name of a local representative visit: www.jordanvalve.com



A Division of Richards Industries
3170 Wasson Road
Cincinnati, OH 45209

toll free. 800.543.7311
local. 513-533.5600
fax. 513.871.0105

email. info@richardsind.com